



# CHEF SYSTEM<sup>®</sup> COOK AND HOLD OVENS

Models CS2-5, CS2-5S, CS2-10, CS2-10S

The Hatco Chef System Cook & Hold Oven roasts meat, poultry and fish, to juicy tenderness... and holds the flavor until ready to serve. Featuring an exclusive **Roast-Air™** process, Chef System uses radiant and convection heat that *browns naturally, tenderizes and holds natural juices*, creating distinctive and tasteful entrees.

## FLEXIBILITY

The Chef System is also available in a smoker model that combines traditional smoking techniques with the Roast-Air process for signature entrees such as salmon, turkey, pork tenderloin, barbecued ribs, brisket and duck. Smoke and hold ovens include 2 lbs. (1 kg) of wood chips.

Choose from models capable of cooking up to 250°F (121°C) or non-smoker models up to 350°F (177°C). All models offer the flexibility to program the oven to cook by the product's internal temperature on the Probe Cook and Hold cycle, by time on the Timed Cook and Hold cycle or with a Manual Timer, which has no hold cycle. Chef System allows the operator to cook in advance of peak periods and hold food for hours.

## QUALITY

- Far less shrinkage – Meats cooked in the Chef System shrink as little as 7-10% compared to 25% in conventional ovens. The savings mean greater profitability.
- Exclusive Roast-Air cooking process combines 90% radiant heat with 10% low velocity convection to brown food naturally.
- Easy-to-use controls combine digital precision with simple dial adjustments. The settings can be changed at any time during the cooking process – preheating, cooking or holding.
- External vents control humidity without losing heat from opening the oven door.
- Power interruption warning – If power is ever lost for more than 10 minutes, the display will indicate the total power interruption time.
- Cleaning made easy – Chef System's stainless steel interior walls, drip pan and chrome wire racks are easily removed for cleaning in a pot and pan sink.
- The drip tray ensures a cleaner work environment.
- Versatility – Slow roast and hold, smoke and hold or bake with Chef System ovens.



Model CS2-5 with optional bumper guards and Carving Station Model GRCSCL-24



Model CS2-5S/CS2-5 with optional bumper guards and accessory stacking hardware



Model CS2-10S with optional bumper guards

METAL SHEATHED ELEMENTS GUARANTEED AGAINST BURNOUT AND BREAKAGE FOR 2 YEARS.



HATCO CORPORATION P.O. Box 340500 Milwaukee, WI 53234-0500 U.S.A.  
 (800) 558-0607 • (414) 671-6350 • Fax (800) 543-7521 • Int'l. Fax (414) 671-3976  
 Web Site: [www.hatcocorp.com](http://www.hatcocorp.com) • E-mail: [equipsales@hatcocorp.com](mailto:equipsales@hatcocorp.com)

Form No. CS2-1001(S)

Printed in U.S.A.



# CHEF SYSTEM<sup>®</sup> COOK AND HOLD OVENS

Models CS2-5, CS2-5S, CS2-10, CS2-10S

\* With standard 4" (10 cm) diameter casters.

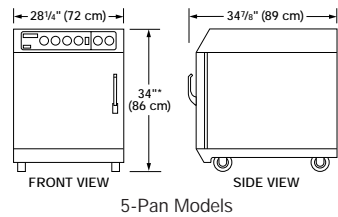

5-Pan Models

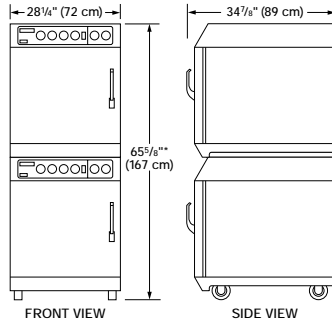

5-Pan Stacked Models

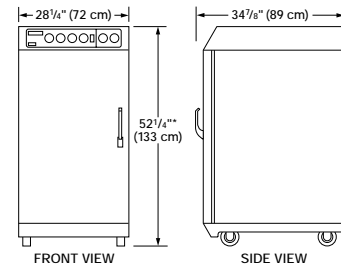

10-Pan Models

## SPECIFICATIONS

### 5-Pan Models

| Model*             | Watts | Product Capacity | Shipping Weight†  |
|--------------------|-------|------------------|-------------------|
| Cook & Hold Ovens  |       |                  |                   |
| CS2-5              | 2170  | 90 lbs. (41 kg)  | 265 lbs. (120 kg) |
| CS2-5L             | 1795  | 90 lbs. (41 kg)  | 265 lbs. (120 kg) |
| Smoke & Hold Ovens |       |                  |                   |
| CS2-5S             | 2320  | 90 lbs. (41 kg)  | 265 lbs. (120 kg) |
| CS2-5SL            | 1945  | 90 lbs. (41 kg)  | 265 lbs. (120 kg) |

\* "L" indicates 120 volt models only. All other models are available in 208, 220 and 240 volts.

† Add 90 lbs. (41 kg) for crates when shipping outside U.S.

### 10-Pan Models

| Model             | Watts | Product Capacity | Shipping Weight†  |
|-------------------|-------|------------------|-------------------|
| Cook & Hold Oven  |       |                  |                   |
| CS2-10            | 2870  | 180 lbs. (82 kg) | 360 lbs. (163 kg) |
| Smoke & Hold Oven |       |                  |                   |
| CS2-10S           | 3020  | 180 lbs. (82 kg) | 360 lbs. (163 kg) |

† Add 90 lbs. (41 kg) for crates when shipping outside U.S.

### 5-Pan Models Stacked

| Model <sup>^</sup>      | Watts     | Product Capacity | Shipping Weight†  |
|-------------------------|-----------|------------------|-------------------|
| Cook & Hold Ovens       |           |                  |                   |
| CS2-5/5                 | 2170 ea.  | 180 lbs. (82 kg) | 530 lbs. (240 kg) |
| Smoke & Hold Ovens      |           |                  |                   |
| CS2-5S/5S               | 2320 ea.  | 180 lbs. (82 kg) | 530 lbs. (240 kg) |
| Smoke/Cook & Hold Ovens |           |                  |                   |
| CS2-5S/5                | 2320/2170 | 180 lbs. (82 kg) | 530 lbs. (240 kg) |

<sup>^</sup> Other combinations available, consult factory.

† Add 90 lbs. (41 kg) per oven for crates when shipping outside U.S.

All models standard with a 250°F (121°C) maximum temperature. 350°F (177°C) models available for 208, 220 and 240 volt non-smoker units, consult factory. 5-Pan models include 2 chrome wire racks and one sheet pan. 10-Pan models include 4 chrome wire racks and one sheet pan. (Quantities for export models vary, consult factory.)

## OPTIONS (NOT FOR RETROFIT)

- 350°F (177°C) Thermostat (Non-Smoker Models)
- Bumper Guards
- Security Package (Locking Control Panel Cover)

## ACCESSORIES

- Carving Station
- Stainless Steel Legs
- Heavy-Duty 5" (13 cm) Diameter Casters

## ARCHITECT SPECS

### Cook & Hold Oven/Smoker

The low-temperature cook & hold oven (smoker) shall be a Chef System<sup>®</sup>, manufactured by the Hatco Corporation, Milwaukee, WI 53234 U.S.A.

The oven (smoker) shall be a Hatco Model ....rated at ....volts and ....watts, with a capacity of ....18" x 26" (46 cm x 66 cm) sheet pans. It shall include 250°F (121°C) thermostat, product probe, power interruption alert, locking door handle, 4" (10 cm) locking casters, chrome wire racks, sheet pan and a 6' (183 cm) attached cord with plug.

The oven shall be made of stainless steel with a positive-latch door, removable interior walls and easy to use controls. Smoker models shall

**HATCO CORPORATION P.O. Box 340500 Milwaukee, WI 53234-0500 U.S.A. • (800) 558-0607 • (414) 671-6350**

**Fax (800) 543-7521 • Int'l. Fax (414) 671-3976 • Web Site: [www.hatcocorp.com](http://www.hatcocorp.com) • E-mail: [equipsales@hatcocorp.com](mailto:equipsales@hatcocorp.com)**

## DIMENSIONS

All Models: 28 1/4" W x 34 7/8" D (72 x 89 cm)

5-Pan: 34" H (86 cm) w/standard casters

10-Pan: 52 1/4" H (133 cm) w/standard casters

Stacking 5-pan: 65 5/8" H (167 cm) w/standard casters

• Add 1" (3 cm) for units with 5" (13 cm) casters. Deduct 2" (5 cm) for units with low profile casters.

## Cabinet Opening

5-Pan: 18 1/4" W x 20 1/2" H (46 x 52 cm)

10-Pan: 18 1/4" W x 38 1/2" H (46 x 98 cm)

## CORD LOCATION

Center of back, 3 1/2" (9 cm) below top of each unit.

## PLUG CONFIGURATIONS

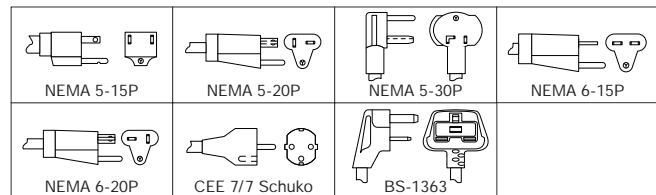

## 5-Pan Models

| Model   | 60 Hz                     |       |       | 50 Hz         |         |
|---------|---------------------------|-------|-------|---------------|---------|
|         | 120V                      | 208V  | 240V  | 220V          | 240V    |
| CS2-5   | -                         | 6-15P | 6-15P | CEE7/7 Schuko | BS-1363 |
| CS2-5L  | 5-15P, 5-20P <sup>†</sup> | -     | -     | -             | -       |
| CS2-5S  | -                         | 6-15P | 6-15P | CEE7/7 Schuko | BS-1363 |
| CS2-5SL | 5-20P, 5-30P <sup>†</sup> | -     | -     | -             | -       |

## 10-Pan Models

| Model   | 60 Hz                     |       | 50 Hz         |         |
|---------|---------------------------|-------|---------------|---------|
|         | 208V                      | 240V  | 220V          | 240V    |
| CS2-10  | 6-15P, 6-20P <sup>†</sup> | 6-15P | CEE7/7 Schuko | BS-1363 |
| CS2-10S | 6-15P, 6-20P <sup>†</sup> | 6-15P | CEE7/7 Schuko | BS-1363 |

<sup>†</sup> For Canada

- Stacking Hardware
- Low Profile Casters
- 18" x 26" (46 x 66 cm) Sheet Pans
- Rib Rack Stainless Steel (13 Slots)
- Wire Racks (Chrome)
- Wire Racks (Stainless)
- 20 Amp Receptacle, 125V (NEMA 5-20R)
- 20 Amp Receptacle, 250V (NEMA 6-20R)

have a removable box to hold wood chips and include 2 lbs. (1 kg) of wood chips. Oven may require exhaust hood, consult local codes.

The solid state controls shall have the capability to program the cooking mode, time, temperature and hold cycle. Audible and visual signals shall announce when the oven (smoker) is ready for cooking. Visual display shall indicate power loss greater than 10 minutes.

Accessories shall include 350°F (177°C) thermostat, perimeter bumpers, stainless rib rack, large 5" (13 cm) and low profile casters, stainless steel legs, security package, chrome wire racks, stainless wire racks and 18" x 26" (46 x 66 cm) sheet pans.